



A deterministic model for Gaussian networks

M. Anand and P. R. Kumar

Department of ECE and CSL, University of Illinois, Urbana, IL 61801

Objective

Capacity and optimal coding schemes for most Gaussian networks are not known. So we try to find answers within a bound. We wish to construct a deterministic network whose capacity differs from that of Gaussian networks by a constant, with the constant independent of channel gains.

System model

- One source-destination pair, many relay nodes.
- Fixed channel gains, Gaussian noise added at receiver.
- Channels are directed wireless links.
- Broadcast and interference assumptions hold.

Linear deterministic model

- Channel allows $\lfloor \log |h|^2 \rfloor$ MSBs of input to pass through.
- Length of each input vector is maximum of all channel capacities.
- Broadcast and interference assumptions still hold.

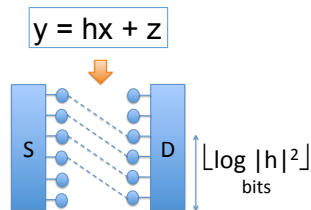

Example

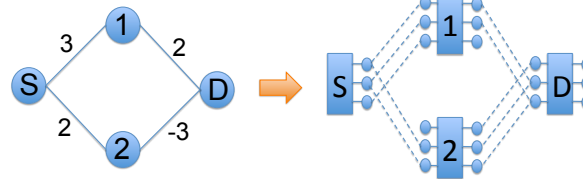

Three Gaussian networks with same linear deterministic counterpart

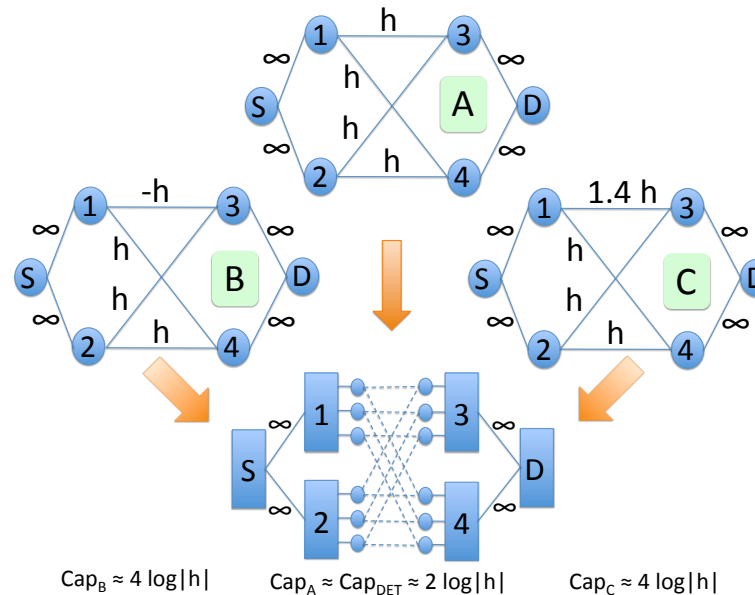

Linear deterministic model is unable to capture phase information in Network B and received signal power in Network C. The model cannot approximate all Gaussian networks.

Deterministic superposition model

- Inputs are positive fractions.
- Channel gains are quantized to nearest integers.
- Channel scales inputs with gains and add them at a receiver.
- Retain integer portion of channel output, discard rest.
- This model has capacity within a bound of the original Gaussian network.

Method of proof

- Cut-set bound is approximately tight for Gaussian and deterministic networks.
- Restrict attention to MIMO channels formed at all cuts.
- Capacity of MIMO channel at every cut is approximately equal for both networks.

Future extensions

- Can we derive optimal coding schemes for Gaussian networks from strategies for deterministic superposition model?
- Can we extend these ideas to multi-terminal Gaussian networks?

